

*Article*

## Oxygen Specific Power Reduction for Air Separation

Yas A. Alsultanny\*, and Nayef N. Al-Shammari

Arabian Gulf University, College of Graduate Studies, Kingdom of Bahrain

\* E-mail: alsultanny@hotmail.com

**Abstract.** Technologies get dated in their life cycles and eventually their cost effectiveness is not as when they were new. One of these significant developments in air separation units is the reduction of regeneration temperature requirement and pressure drop across Molecular Sieve, which were expected to reduce the total power consumption. The impact of these expected developments were evaluated on oxygen specific power. The two developments methods were tested in this paper. The first method was the adoption of new molecular sieve that will consume less power than the current molecular sieve by 50%. The second development method was the modification of vessel layout, where two bed of molecular sieve can be used, which will reduce the pressure drop across molecular sieve system. The effect of these two methods was evaluated on oxygen specific power. The results showed that a negligible impact on oxygen specific power in case of the modification of vessel layout, where a significant impact in oxygen specific power was noticed by adoption of a new molecular sieve that consumes lower power than the current. This encourages the investment on molecular sieve development not on modifying the layout of vessel for the purpose of pressure drop reduction.

**Keywords:** Technological forecasting, air separation unit, oxygen specific power, molecular sieve.

ENGINEERING JOURNAL Volume 17 Issue 1

Received 17 July 2012

Accepted 17 September 2012

Published 1 January 2013

Online at <http://www.engj.org/>

DOI:10.4186/ej.2013.17.1.121

## 1. Introduction

Technological Forecasting (TF) became one of the important tools of technology management, its significance increased dramatically parallel to the increment on innovations number and the open market resulted by Globalization. It played a strong role in technology's life cycles.

Competitiveness and performance of all industrial organizations are greatly affected by the technological capabilities of these organizations, which are broadly determined by the technological regime in which the organizations operate. The industrial sectors started as projects, which rest on different technologies either for making a product or for providing a service, the decisions need to be made in all phases of technology's life cycle. However, technologies get dated with time and their cost effectiveness will not be as good as the cost effectiveness of new technologies [1, 2].

Meredith and Mantel [1] defined Technological Forecasting as the process of predicting the future characteristics and timing of technology, it is an important process to have accurate judgment and decision-making or at least close to the right one.

All Market leaders believed on one common vision, to be a leader in their field and they believed on the effect of the technological developments in their competitiveness in the market and the significance of TF in assessing the current technologies as a part of technology management role [3]. Adoption of new technologies introduces new risks for the society and TF used to mitigate these risks [4].

## 2. Technological Forecasting Methods Selection

Characteristics of different technologies are not the same, moreover the development rate for technologies are not identical. TF application required data gathering, where data availability are not the same for all technologies, these differences led researchers to develop methodologies to match TF methods to a technology, that is going to be forecasted, which enhanced TF methods selection. Mapping TF methods to technologies required some alignment based on the characteristics of both technologies and TF methods [5].

Application of single TF method is not leading to the required strength in forecasting results, many factors can affect TF results, and these may be captured by using alternative approaches. Combining can reduce errors arising from faulty assumptions, bias, or mistakes in data, a single TF not recommended to be used alone and combining forecasts is an appealing approach will enhance the accuracy of TF results [6].

Wang and Lan recommended combining scenario analysis with substitution model, since scenario analysis is not capable to provide sustained quantitative forecasts, while substitution model offers quantitative forecasts but the influence of causative agent(s) will not be considered, which leads to weakness in forecasting results. Their study showed the necessity for combining these two methods, since they are complementary for each other [7].

Combining TF became common practice by most of researcher for example, scenario analysis, Delphi, and the technological substitution model were used together to forecast organic light-emitting diode [8].

## 3. Air Separation Units

Air Separation processes known as separation of industrial gases like oxygen, nitrogen and argon gases from air in large scale. Thorogood considered air cryogenic air separation mature technologies [9]. However, his consideration is not valid any more since many patents published in cryogenic air separation and ongoing developments, 429 US patents were disclosed in 1990 to 1999 for air separation process, 40-45% of these patents were related to cryogenic air separation. It was stated that there seems to be plenty of room for innovation in air separation process [9-11].

Vinson stated that ASU technology is not a mature technology since significant advances continue to be made in the design efficiency and operating optimization of these processes [12]. This advances were driven by the recent rise in energy prices, which will drive further improvements in the industry, and may catalyze additional research aimed at further improvements in control and operability of air separation processes [12].

Generally the industrial gas processing is classified into two main categories:

- Non-cryogenic industrial gas processing
- Cryogenic industrial gas processing

Figure 1 illustrates the classification of air separation units by showing the sub technologies in each class.

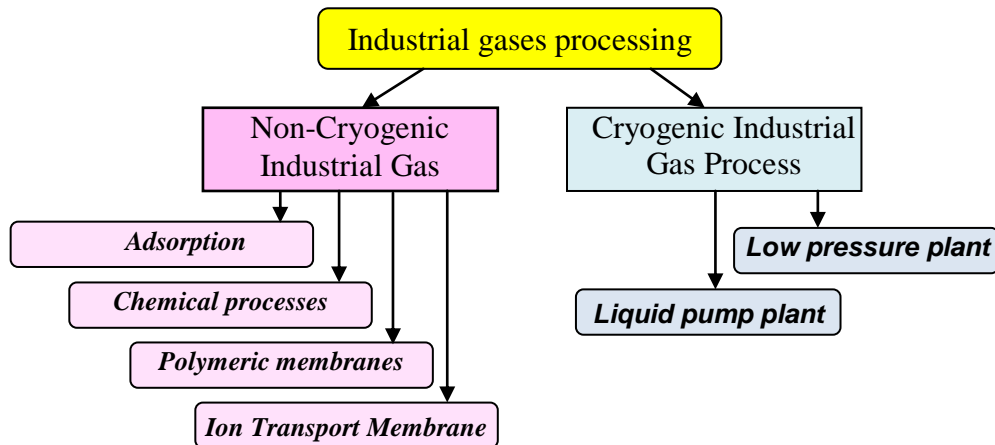

Fig. 1. Classification of industrial gas processing.

#### 4. Air Separation Unit ASU-51

The air separation unit used in this paper (ASU-51) was classified as a cryogenic liquid pump plant as shown in Fig. 2. It was equipped with internal compression pump (IC-Pump). The unit is designed to produce 2682 metric ton/day of oxygen, which is equivalent to 78225 Nm<sup>3</sup>/hr.

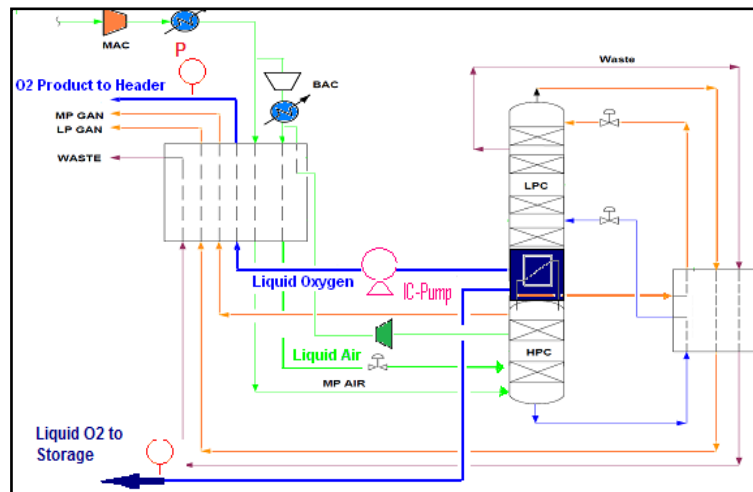

Fig. 2. Location of O<sub>2</sub> production readings in ASU-51. LP GOX: Low pressure oxygen, HP GOX: High pressure gas oxygen, MP GAN: Medium pressure gas nitrogen, LP GAN: Low pressure gas nitrogen, MAC: Main air compressor, BAC: Booster air compressor, and IC-Pump: Internal compression pump.

It has only one measuring point for oxygen gas (P). The total power consumption of the unit is collected by adding all the power consumption of equipments involved in oxygen production as follows:

- Power of air compressors
- Power of regeneration heaters
- Power of all pumps involved in production

The oxygen specific power is calculated by the following equation:

$$O_2 \text{ Specific power (Kw/Nm}^3) = \frac{\text{Total power consumed (Kw/hr)}}{\text{Total O}_2 \text{ production in (Nm}^3\text{/hr)}} \quad (1)$$

Table 1 shows the data collected for the unit with the calculated oxygen specific power.

Table 1. Power consumption, oxygen production and specific power.

No.	Date	Total power consumption (Kw/hr)	Total O <sub>2</sub> production (Nm <sup>3</sup> /hr)	Specific power (Kw/Nm <sup>3</sup> )
1.	8/9/2009	48674	20652	2.357 (executed)
2.	9/9/2009	51222	76161	0.673 (used as an example)
3.	10/9/2009	50952	75285	0.677
4.	11/9/2009	50513	74861	0.675
5.	12/9/2009	50683	75193	0.674
6.	13/9/2009	50702	75294	0.673
7.	14/9/2009	50800	74936	0.678
8.	15/9/2009	50884	74450	0.683
9.	16/9/2009	50735	75058	0.676
10.	17/9/2009	50707	75012	0.676
11.	18/9/2009	50430	74230	0.679
12.	19/9/2009	49090	70886	0.693
13.	20/9/2009	48837	70445	0.693
14.	21/9/2009	48737	70451	0.692
15.	22/9/2009	48797	70466	0.692
16.	23/9/2009	48549	69946	0.694
17.	24/9/2009	48519	70130	0.692
18.	25/9/2009	48200	69494	0.694
19.	26/9/2009	47976	69419	0.691
20.	27/9/2009	48003	69948	0.686
21.	28/09/2009	48057	70426	0.682
22.	29/09/2009	47961	69928	0.686
23.	30/09/2009	48067	70054	0.686
24.	01/10/2009	48162	69305	0.695
25.	02/10/2009	48059	70164	0.685
26.	03/10/2009	49806	73180	0.681
27.	04/10/2009	50228	73703	0.681
28.	05/10/2009	48290	69930	0.691
29.	06/10/2009	46138	57397	0.804 <sup>1</sup>
30.	07/10/2009	48751	70352	0.693
31.	08/10/2009	50623	74578	0.679
32.	09/10/2009	51734	77313	0.669
33.	10/10/2009	52897	79453	0.666
34.	11/10/2009	53017	79787	0.664
35.	12/10/2009	53046	79829	0.664
36.	13/10/2009	53034	79595	0.666
37.	14/10/2009	52938	79315	0.667
38.	15/10/2009	52995	79107	0.670
39.	16/10/2009	51921	77472	0.670
40.	17/10/2009	47081	67480	0.698
41.	18/10/2009	47030	68331	0.688
42.	19/10/2009	47152	68617	0.687
43.	20/10/2009	47443	68707	0.691
44.	21/10/2009	47082	68188	0.690
45.	22/10/2009	46880	67972	0.690
46.	23/10/2009	46977	67721	0.694
47.	24/10/2009	47005	67718	0.694
48.	25/10/2009	47075	67987	0.692
49.	26/10/2009	47051	67398	0.698
50.	27/10/2009	47120	67097	0.702 (Highest Value)
51.	28/10/2009	47020	67836	0.693
52.	29/10/2009	46839	68490	0.684
53.	30/10/2009	46716	67948	0.688
54.	31/10/2009	47218	67861	0.696
55.	01/11/2009	50941	74635	0.683
56.	02/11/2009	54025	79843	0.677

57. 03/11/2009	52920	77583	0.682
58. 04/11/2009	51990	77137	0.674
59. 05/11/2009	53949	80613	0.669
60. 06/11/2009	53807	80509	0.668
61. 07/11/2009	53762	80691	0.666
62. 08/11/2009	53774	80584	0.667
63. 09/11/2009	53653	80810	0.664
64. 10/11/2009	53574	80674	0.664
65. 11/11/2009	51549	76928	0.670
66. 12/11/2009	51419	76703	0.670
67. 13/11/2009	51189	76696	0.667
68. 14/11/2009	50277	75030	0.670
69. 15/11/2009	48894	72139	0.678
70. 16/11/2009	53552	80836	0.662
71. 17/11/2009	53776	81208	0.662
72. 18/11/2009	53838	81901	0.657
73. 19/11/2009	53277	80902	0.659
74. 20/11/2009	47912	69666	0.688
75. 21/11/2009	20697	19904	1.040 <sup>1</sup>
76. 22/11/2009	35290	9238	3.820 <sup>1</sup>
77. 23/11/2009	46484	64280	0.723 <sup>1</sup>
78. 24/11/2009	46444	68695	0.676
79. 25/11/2009	47526	70751	0.672
80. 26/11/2009	48897	72713	0.672
81. 27/11/2009	53100	80673	0.658
82. 28/11/2009	53695	81008	0.663
83. 29/11/2009	53389	81129	0.658
84. 30/11/2009	53040	81049	0.654
85. 01/12/2009	53129	81136	0.655
86. 02/12/2009	52977	81246	0.652
87. 03/12/2009	53081	81322	0.653
88. 04/12/2009	53279	81401	0.655
89. 05/12/2009	53235	81959	0.650
90. 06/12/2009	53700	83169	0.646
91. 07/12/2009	53870	83169	0.648
92. 08/12/2009	53583	83292	0.643
93. 09/12/2009	53607	83221	0.644
94. 10/12/2009	53567	83266	0.643
95. 11/12/2009	53202	83294	0.639 (Lowest Value)
96. 12/12/2009	53465	82927	0.645
97. 13/12/2009	52893	81923	0.646
98. 14/12/2009	48943	73118	0.669
99. 15/12/2009	50805	75349	0.674
100.16/12/2009	52074	78666	0.662
101.17/12/2009	53207	80731	0.659
102.18/12/2009	53105	80568	0.659
103.19/12/2009	53578	81354	0.659
104.20/12/2009	53312	81282	0.656
105.21/12/2009	53140	81567	0.651
106.22/12/2009	53136	81499	0.652
107.23/12/2009	53436	81511	0.656
108.24/12/2009	53546	81300	0.659
109.25/12/2009	54706	83278	0.657
<b>Average</b>	<b>50760</b>	<b>75337</b>	<b>0.672 (Kw/ Nm<sup>3</sup>)</b>

The average of the total power consumption is 50760 Kw/hr and the average of the total oxygen production is 75337 Nm<sup>3</sup>/hr, this production is near to the designed production value of 78225 Nm<sup>3</sup>/hr, which means the production was 3.6% less than the designed production, which is within the acceptable limit, determined by  $\pm 5\%$ . The oxygen specific power ranged between 0.639 kw/Nm<sup>3</sup> and 0.702 Kw/Nm<sup>3</sup>, and the total oxygen production ranged between 67096 Nm<sup>3</sup>/hr and 83293 Nm<sup>3</sup>/hr.

Running the plant in turndown mode as in case of less oxygen demand, increased the oxygen specific power from 0.639 to 0.702 Kw/Nm<sup>3</sup>, thus an additional 0.063 Kw/Nm<sup>3</sup> was added to the power consumption per one normal cubic meter of oxygen production, i.e.:

$$\begin{aligned} 0.063 \text{ Kw/Nm}^3 * 67000 \text{ Nm}^3/\text{hr} &= 4221 \text{ Kw/hr} \\ &= 4.221 \text{ Mw/hr} \\ &= 4.221 \text{ Mw/hr} * 32 \text{ \$/Mw} = 135 \text{ \$/hr} \end{aligned}$$

If the price of each Mw is 32\$, which means saving 135 \$ if the unit is running with the maximum production rate, the saving can be 135 \$ \* 24 hr \* 365 = 1182600 \$/year.

## 5. Technological Forecasting for Cryogenic Air Separation Units

Cryogenic air separation units were considered to be the most cost effective technologies used for industrial gas production for large quantities and high purity. *Bibliometric* and *patents* review showed that intensive developments took place in cryogenic ASU technologies, focused on the following scopes:

- To increase the production quantities and improve the quality of the products
- To improve the safety level, and reduce the impact of pollution on ASU performance
- To reduce the power consumption associated with production

This paper focused on the developments that may reduce the power consumption of ASUs and especially in purification system since it consumes most of the ASUs power.

The purification system at ASU is used to extract impurities such as water vapor, CO<sub>2</sub>, nitrogen oxide, and other pollutant from the air, where their present will lead to their freezing and creates chocks in the cryogenic units, their present may cause exposition in some cases, this system consist of reverse heat exchanger (REVEX) in their early years. Technological forecasting showed that REVEX is an obsolete technology as it consumes about 50% of ASU power. This technology was replaced by the molecular sieve (MS) technology, which is used in the unit of our case study. The patents review also showed that most of the development was done in purification system, where molecular sieves were used. The adsorption capability and heat consumption are the areas of interest in these developments [13].

Figure 3 shows the general layout of the MS system which consists of two beds of molecular sieve. In normal operation, one bed will be in service, where it will absorb the water vapor and pollutants gases, and the other one will be under regeneration, where waste nitrogen is heated and used for regeneration of saturated bed and removing the adsorbed water vapor and pollutants. During the regeneration steps, the outlet temperature needs to be approximately 120°C, which is the requirement for full regeneration of used molecular sieve.

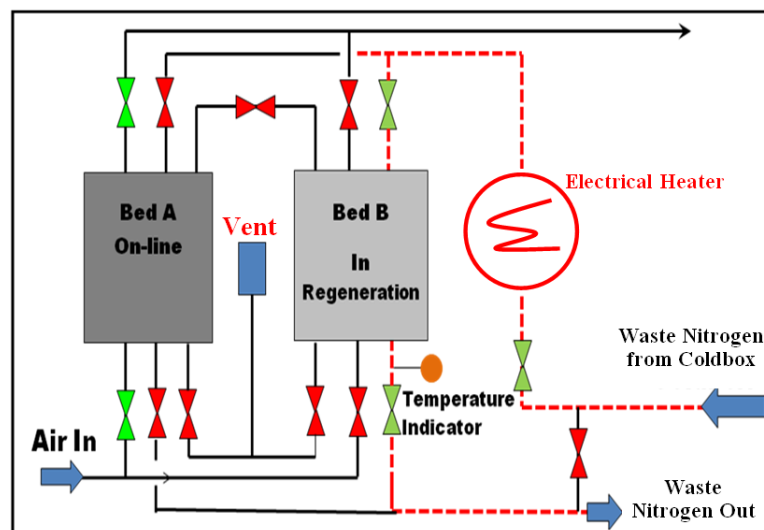

Fig. 3. Molecular sieve layout of ASU.

The technological forecasting through patents review of MS showed that the regeneration temperature was about 200°C and improved further to 150°C [14]. The current regeneration temperature of the unit used in this research is around 120°. The following data will be used in TF extrapolation:

- 200°C [14]
- 150°C [14]
- 120°C (from the current reading of the unit used in this research)

The extrapolation method used to forecast the future regeneration temperature. Figure 4 shows that the regenerated temperature is expected to be reduced to about (60°C) before year 2020, which means that there will be (50%) reduction for the heater power consumption.

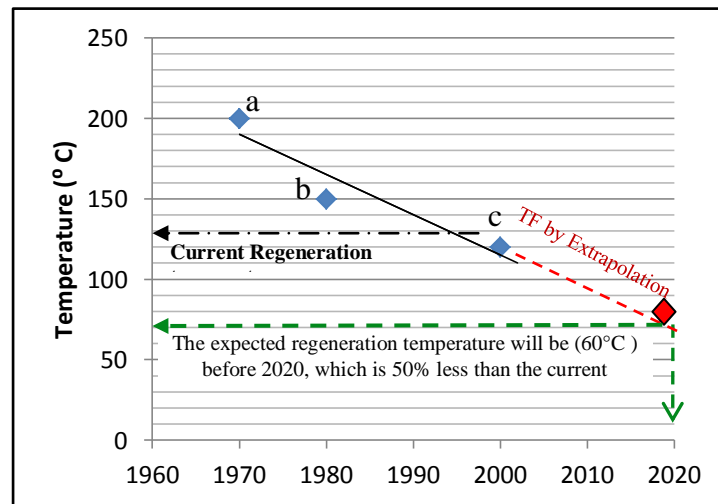

Fig. 4. Regeneration temperature required vs. years.

Patent review showed a new layout of MS vessels, where two vessels can be used in service instead of one, this will reduce the pressure drop across the MS system to about (50%). Figure 5 shows the new layout of MS vessels where the pressure drops are expected to be lowered by 50%. The reduction in the pressure drop across ASU unit will reduce the power consumption. Using two MS beds will reduce the pressure drop to (50%) and reduce the power consumption of main air compressor (MAC) [15].

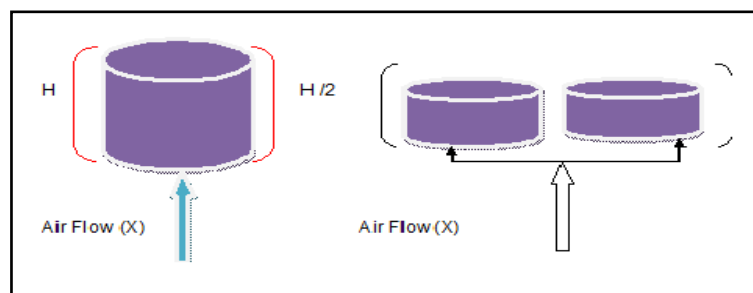

Fig. 5. Reduction in bed depth.

## 6. Impact of Forecasted Developments on Oxygen Specific Power

Strategic planning and decision-making need to be supported by forecasting the impact of the forecasted development. Two suggested developments on ASU are:

- Development of a new molecular sieve which consumes 50% less power than the current power required for the regeneration process
- Modification of molecular sieve layout, where two beds can be used in parallel to reducing the pressure drop, which will also reduce the power consumption

For the technological forecasting to the unit selected in this research, by adjusting the power consumption to 50% reduction of power consumption for temperature regeneration. The oxygen specific power was calculated by using the reading obtained from the unit used in this research. Table 2 shows the result of the recalculations.

Table 2. Impact of the first development on performance.

No.	Date	Actual total power consumption (Kw/hr)	Total O <sub>2</sub> production (Nm <sup>3</sup> /hr)	Actual specific MS-heaters power (Kw/Nm <sup>3</sup> )	Forecasted specific power (Kw/hr)	Forecasted specific power (Kw/Nm <sup>3</sup> )	Reduction in specific power (Kw/Nm <sup>3</sup> )
1	08/09/2009	48674	20652	2.360	1321	2.325	0.035
2	09/09/2009	51222	76161	0.673	1522	0.663	0.010
3	10/09/2009	50952	75285	0.677	1717	0.665	0.011
4	11/09/2009	50513	74861	0.675	1694	0.663	0.011
5	12/09/2009	50683	75193	0.674	1645	0.663	0.011
6	13/09/2009	50702	75294	0.673	1638	0.663	0.011
7	14/09/2009	50800	74936	0.678	1675	0.667	0.011
8	15/09/2009	50884	74450	0.683	1666	0.672	0.011
9	16/09/2009	50735	75058	0.676	1582	0.665	0.011
10	17/09/2009	50707	75012	0.676	1615	0.665	0.011
11	18/09/2009	50430	74230	0.679	1650	0.668	0.011
12	19/09/2009	49090	70886	0.693	1643	0.681	0.012
13	20/09/2009	48837	70444	0.693	1543	0.682	0.011
14	21/09/2009	48737	70451	0.692	1722	0.680	0.012
15	22/09/2009	48797	70466	0.692	1698	0.680	0.012
16	23/09/2009	48549	69946	0.694	1727	0.682	0.012
17	24/09/2009	48519	70130	0.692	1707	0.680	0.012
18	25/09/2009	48200	69494	0.694	1659	0.682	0.012
19	26/09/2009	47976	69419	0.691	1433	0.681	0.010
20	27/09/2009	48003	69948	0.686	1678	0.674	0.012
21	28/09/2009	48057	70426	0.682	1776	0.670	0.013
22	29/09/2009	47961	69928	0.686	1692	0.674	0.012
23	30/09/2009	48067	70054	0.686	1605	0.675	0.011
24	01/10/2009	48162	69305	0.695	1601	0.683	0.012
25	02/10/2009	48059	70164	0.685	1601	0.674	0.011
26	03/10/2009	49806	73180	0.681	1631	0.669	0.011
27	04/10/2009	50228	73703	0.681	1660	0.670	0.011
28	05/10/2009	48290	69930	0.691	1644	0.679	0.012
29	06/10/2009	46138	57397	0.804	1637	0.790	0.014
30	07/10/2009	48751	70352	0.693	1649	0.681	0.012
31	08/10/2009	50623	74578	0.679	1640	0.668	0.011
32	09/10/2009	51734	77313	0.669	1647	0.658	0.011
33	10/10/2009	52897	79453	0.666	1615	0.656	0.010
34	11/10/2009	53017	79787	0.664	1632	0.654	0.010
35	12/10/2009	53046	79829	0.664	1636	0.654	0.010
36	13/10/2009	53034	79595	0.666	1724	0.655	0.011
37	14/10/2009	52938	79314	0.667	1765	0.656	0.011
38	15/10/2009	52995	79107	0.670	1749	0.659	0.011
39	16/10/2009	51921	77472	0.670	1767	0.659	0.011
40	17/10/2009	47081	67480	0.698	1785	0.684	0.013
41	18/10/2009	47030	68331	0.688	1524	0.677	0.011
42	19/10/2009	47152	68617	0.687	1503	0.676	0.011
43	20/10/2009	47443	68707	0.691	1778	0.678	0.013
44	21/10/2009	47082	68188	0.690	1718	0.678	0.013
45	22/10/2009	46880	67972	0.690	1542	0.678	0.011
46	23/10/2009	46977	67721	0.694	1547	0.682	0.011
47	24/10/2009	47005	67718	0.694	1564	0.683	0.012
48	25/10/2009	47075	67987	0.692	1643	0.680	0.012
49	26/10/2009	47051	67398	0.698	1660	0.686	0.012
50	27/10/2009	47120	67097	0.702	1700	0.690	0.013



51	28/10/2009	47020	67836	0.693	1743	0.680	0.013
52	29/10/2009	46839	68490	0.684	1598	0.672	0.012
53	30/10/2009	46716	67948	0.688	1380	0.677	0.010
54	31/10/2009	47218	67861	0.696	1718	0.683	0.013
55	01/11/2009	50941	74635	0.683	1707	0.671	0.011
56	02/11/2009	54025	79843	0.677	1723	0.666	0.011
57	03/11/2009	52920	77583	0.682	1700	0.671	0.011
58	04/11/2009	51990	77137	0.674	1459	0.665	0.009
59	05/11/2009	53949	80613	0.669	1637	0.659	0.010
60	06/11/2009	53807	80509	0.668	1756	0.657	0.011
61	07/11/2009	53762	80691	0.666	1750	0.655	0.011
62	08/11/2009	53774	80584	0.667	1764	0.656	0.011
63	09/11/2009	53653	80810	0.664	1756	0.653	0.011
64	10/11/2009	53574	80674	0.664	1794	0.653	0.011
65	11/11/2009	51549	76928	0.670	1729	0.659	0.011
66	12/11/2009	51419	76703	0.670	1769	0.659	0.012
67	13/11/2009	51189	76696	0.667	1750	0.656	0.011
68	14/11/2009	50277	75030	0.670	1747	0.658	0.012
69	15/11/2009	48894	72139	0.678	1754	0.666	0.012
70	16/11/2009	53552	80836	0.662	1856	0.651	0.011
71	17/11/2009	53776	81208	0.662	1895	0.651	0.012
72	18/11/2009	53838	81901	0.657	1731	0.647	0.011
73	19/11/2009	53277	80902	0.659	1700	0.648	0.011
74	20/11/2009	47912	69666	0.688	1682	0.676	0.012
75	21/11/2009	20697	72806	0.705	849	0.278	0.426
76	22/11/2009	35290	73511	0.682	1575	0.469	0.213
77	23/11/2009	46484	64280	0.723	1498	0.712	0.012
78	24/11/2009	46444	68695	0.676	1594	0.664	0.012
79	25/11/2009	47526	70751	0.672	1655	0.660	0.012
80	26/11/2009	48897	72713	0.672	1680	0.661	0.012
81	27/11/2009	53100	80673	0.658	1449	0.649	0.009
82	28/11/2009	53695	81008	0.663	1772	0.652	0.011
83	29/11/2009	53389	81129	0.658	1606	0.648	0.010
84	30/11/2009	53040	81049	0.654	1581	0.645	0.010
85	01/12/2009	53129	81136	0.655	1783	0.644	0.011
86	02/12/2009	52977	81246	0.652	1589	0.642	0.010
87	03/12/2009	53081	81322	0.653	1589	0.643	0.010
88	04/12/2009	53279	81401	0.655	1770	0.644	0.011
89	05/12/2009	53235	81959	0.650	1517	0.640	0.009
90	06/12/2009	53700	83169	0.646	1687	0.636	0.010
91	07/12/2009	53870	83169	0.648	1776	0.637	0.011
92	08/12/2009	53583	83292	0.643	1462	0.635	0.009
93	09/12/2009	53607	83221	0.644	1722	0.634	0.010
94	10/12/2009	53567	83265	0.643	1759	0.633	0.011
95	11/12/2009	53202	83294	0.639	1438	0.630	0.009
96	12/12/2009	53465	82927	0.645	1773	0.634	0.011
97	13/12/2009	52893	81923	0.646	1681	0.635	0.010
98	14/12/2009	48943	73118	0.669	1588	0.659	0.011
99	15/12/2009	50805	75349	0.674	1767	0.663	0.012
100	16/12/2009	52074	78666	0.662	1523	0.652	0.010
101	17/12/2009	53207	80731	0.659	1832	0.648	0.011
102	18/12/2009	53105	80568	0.659	1463	0.650	0.009
103	19/12/2009	53578	81354	0.659	1831	0.647	0.011
104	20/12/2009	53312	81282	0.656	1802	0.645	0.011
105	21/12/2009	53140	81567	0.651	1561	0.642	0.010
106	22/12/2009	53136	81499	0.652	1547	0.642	0.009
107	23/12/2009	53436	81511	0.656	1788	0.645	0.011
108	24/12/2009	53546	81300	0.659	1808	0.647	0.011
109	25/12/2009	54706	83278	0.657	1750	0.646	0.011
<b>Average</b>		<b>50345</b>	<b>74915</b>	<b>0.690</b>	<b>1654</b>	<b>0.673</b>	<b>0.017</b>

The following is an example of this calculation as shown in row 2 of Table 2:

$$\begin{aligned} \text{Actual Total Power Consumption} &= 51222 \text{ Kw/hr} \\ \text{Total O}_2 \text{ Production} &= 76161 \text{ Nm}^3/\text{hr} \\ \text{Actual Specific Power} &= 51222/76161 = 0.673 \text{ Kw/Nm}^3 \end{aligned}$$

Application for extrapolation method of TF is shown in Fig. 4, which shows that there will be 50% reduction in the temperature requirement of the new molecular sieve, and will reduce the total power consumption and reduce the oxygen specific power as per the following formula:

$$\text{Forecasted specific power} = \frac{\text{Actual total power consumption} - 50\% \text{ of MS-heaters power}}{\text{Total O}_2 \text{ production}} \quad (2)$$

Forecasted Specific Power =  $(51222 - 1522 \times 0.5)/76161 = 0.663 \text{ Kw/Nm}^3$  as for row 2 of Table 2.

The second suggested development was done to forecast the impact of using two beds in parallel, where the pressure drop was expected to be lowered by 50% as disclosed by [14]. ASU-51 was selected to forecast the impact of the second development on performance. The pressure drop across the molecular sieve is about  $0.056 \text{ Kg/cm}^2$  as per the specification.

The power required to build up pressure of  $1 \text{ kg/cm}^2$  was measured  $24.3/4.37 = 5.5 \text{ Mw/hr/Kg/cm}^2$  as shown in Fig. 6, where  $24.3 \text{ Mw/hr}$  is the difference in power consumption of the main air compressor (MAC) and  $4.32 \text{ Kg/cm}^2$  is the difference in discharge pressure of the MAC before and after the startup. The effect of forecasted 50% reduction in pressure drop is expected to be  $0.056/2 = 0.028 \text{ Kg/cm}^2$  as per Seaton [14], which is equivalent to a reduction in power by  $0.028 \text{ Kg/Cm}^2 \times 5.5 \text{ Mw/hr /Kg/cm}^2 = 0.154 \text{ Mw/hr} = 154 \text{ Kw/hr}$ . This value was subtracted from each value of the total power and the specific power, and then recalculated by using the new power consumption as shown in Table 3.

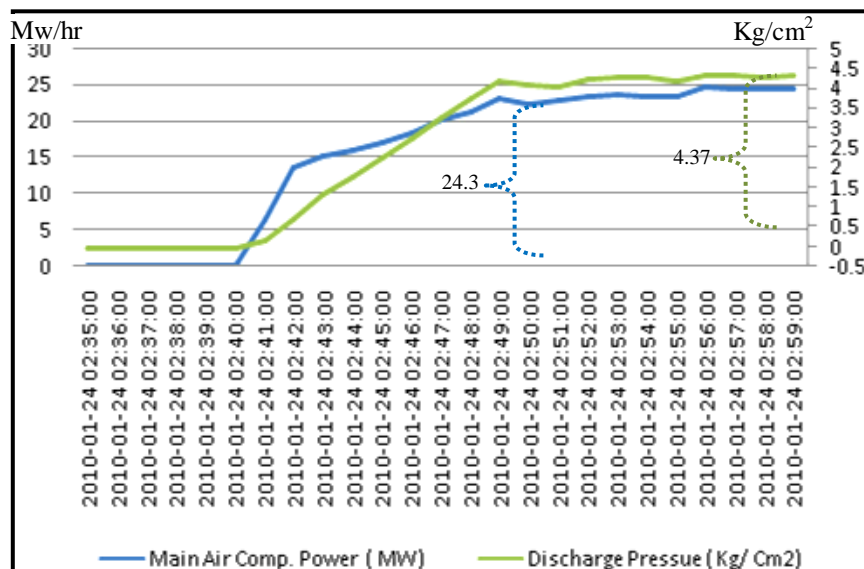

Fig. 6. Main air compressor power vs. discharge pressure.

The following is an example for the impact of the second development as shown in row 2 of Table 3:

$$\begin{aligned} \text{Actual Total Power Consumption} &= 51222 \text{ Kw/hr} \\ \text{Total O}_2 \text{ Production} &= 76161 \text{ Nm}^3/\text{hr} \\ \text{Actual Specific Power} &= 51222/76161 = 0.673 \text{ Kw/Nm}^3 \end{aligned}$$

$$\text{Forecasted specific power} = \frac{\text{Actual total power consumption} - \text{Power reduction with two beds}}{\text{Total O}_2 \text{ production}} \quad (3)$$

$$\text{Forecasted Specific Power} = (51222 - 154)/76161 = 0.671 \text{ Kw/Nm}^3$$

Table 3. Impact of the second development on oxygen specific power.

No.	Date	Actual total power consumption (Kw/hr)	Total O <sub>2</sub> production (Nm <sup>3</sup> /hr)	Actual specific power (Kw/Nm <sup>3</sup> )	Power reduction resulted by using two bed	Forecasted specific power (Kw/Nm <sup>3</sup> )	Reduction in specific power (Kw/Nm <sup>3</sup> )
1	08/09/2009	48674	20652	2.360	154	2.349	0.011
2	09/09/2009	51222	76161	0.673	154	0.671	0.002
3	10/09/2009	50952	75285	0.677	154	0.675	0.002
4	11/09/2009	50513	74861	0.675	154	0.673	0.002
5	12/09/2009	50683	75193	0.674	154	0.672	0.002
6	13/09/2009	50702	75294	0.673	154	0.671	0.002
7	14/09/2009	50800	74936	0.678	154	0.676	0.002
8	15/09/2009	50884	74450	0.683	154	0.681	0.002
9	16/09/2009	50735	75058	0.676	154	0.674	0.002
10	17/09/2009	50707	75012	0.676	154	0.674	0.002
11	18/09/2009	50430	74230	0.679	154	0.677	0.002
12	19/09/2009	49090	70886	0.693	154	0.690	0.002
13	20/09/2009	48837	70444	0.693	154	0.691	0.002
14	21/09/2009	48737	70451	0.692	154	0.690	0.002
15	22/09/2009	48797	70466	0.692	154	0.690	0.002
16	23/09/2009	48549	69946	0.694	154	0.692	0.002
17	24/09/2009	48519	70130	0.692	154	0.690	0.002
18	25/09/2009	48200	69494	0.694	154	0.691	0.002
19	26/09/2009	47976	69419	0.691	154	0.689	0.002
20	27/09/2009	48003	69948	0.686	154	0.684	0.002
21	28/09/2009	48057	70426	0.682	154	0.680	0.002
22	29/09/2009	47961	69928	0.686	154	0.684	0.002
23	30/09/2009	48067	70054	0.686	154	0.684	0.002
24	01/10/2009	48162	69305	0.695	154	0.693	0.002
25	02/10/2009	48059	70164	0.685	154	0.683	0.002
26	03/10/2009	49806	73180	0.681	154	0.678	0.002
27	04/10/2009	50228	73703	0.681	154	0.679	0.002
28	05/10/2009	48290	69930	0.691	154	0.688	0.002
29	06/10/2009	46138	57397	0.804	154	0.801	0.003
30	07/10/2009	48751	70352	0.693	154	0.691	0.002
31	08/10/2009	50623	74578	0.679	154	0.677	0.002
32	09/10/2009	51734	77313	0.669	154	0.667	0.002
33	10/10/2009	52897	79453	0.666	154	0.664	0.002
34	11/10/2009	53017	79787	0.664	154	0.663	0.002
35	12/10/2009	53046	79829	0.664	154	0.663	0.002
36	13/10/2009	53034	79595	0.666	154	0.664	0.002
37	14/10/2009	52938	79314	0.667	154	0.665	0.002
38	15/10/2009	52995	79107	0.670	154	0.668	0.002
39	16/10/2009	51921	77472	0.670	154	0.668	0.002
40	17/10/2009	47081	67480	0.698	154	0.695	0.002
41	18/10/2009	47030	68331	0.688	154	0.686	0.002
42	19/10/2009	47152	68617	0.687	154	0.685	0.002
43	20/10/2009	47443	68707	0.691	154	0.688	0.002
44	21/10/2009	47082	68188	0.690	154	0.688	0.002
45	22/10/2009	46880	67972	0.690	154	0.687	0.002
46	23/10/2009	46977	67721	0.694	154	0.691	0.002
47	24/10/2009	47005	67718	0.694	154	0.692	0.002
48	25/10/2009	47075	67987	0.692	154	0.690	0.002
49	26/10/2009	47051	67398	0.698	154	0.696	0.002
50	27/10/2009	47120	67097	0.702	154	0.700	0.002
51	28/10/2009	47020	67836	0.693	154	0.691	0.002
52	29/10/2009	46839	68490	0.684	154	0.682	0.002
53	30/10/2009	46716	67948	0.688	154	0.685	0.002

54	31/10/2009	47218	67861	0.696	154	0.694	0.002
55	01/11/2009	50941	74635	0.683	154	0.680	0.002
56	02/11/2009	54025	79843	0.677	154	0.675	0.002
57	03/11/2009	52920	77583	0.682	154	0.680	0.002
58	04/11/2009	51990	77137	0.674	154	0.672	0.002
59	05/11/2009	53949	80613	0.669	154	0.667	0.002
60	06/11/2009	53807	80509	0.668	154	0.666	0.002
61	07/11/2009	53762	80691	0.666	154	0.664	0.002
62	08/11/2009	53774	80584	0.667	154	0.665	0.002
63	09/11/2009	53653	80810	0.664	154	0.662	0.002
64	10/11/2009	53574	80674	0.664	154	0.662	0.002
65	11/11/2009	51549	76928	0.670	154	0.668	0.002
66	12/11/2009	51419	76703	0.670	154	0.668	0.002
67	13/11/2009	51189	76696	0.667	154	0.665	0.002
68	14/11/2009	50277	75030	0.670	154	0.668	0.002
69	15/11/2009	48894	72139	0.678	154	0.676	0.002
70	16/11/2009	53552	80836	0.662	154	0.661	0.002
71	17/11/2009	53776	81208	0.662	154	0.660	0.002
72	18/11/2009	53838	81901	0.657	154	0.655	0.002
73	19/11/2009	53277	80902	0.659	154	0.657	0.002
74	20/11/2009	47912	69666	0.688	154	0.686	0.002
75	21/11/2009	20697	72806	0.705	154	0.282	0.422
76	22/11/2009	35290	73511	0.682	154	0.478	0.204
77	23/11/2009	46484	64280	0.723	154	0.721	0.002
78	24/11/2009	46444	68695	0.676	154	0.674	0.002
79	25/11/2009	47526	70751	0.672	154	0.670	0.002
80	26/11/2009	48897	72713	0.672	154	0.670	0.002
81	27/11/2009	53100	80673	0.658	154	0.656	0.002
82	28/11/2009	53695	81008	0.663	154	0.661	0.002
83	29/11/2009	53389	81129	0.658	154	0.656	0.002
84	30/11/2009	53040	81049	0.654	154	0.653	0.002
85	01/12/2009	53129	81136	0.655	154	0.653	0.002
86	02/12/2009	52977	81246	0.652	154	0.650	0.002
87	03/12/2009	53081	81322	0.653	154	0.651	0.002
88	04/12/2009	53279	81401	0.655	154	0.653	0.002
89	05/12/2009	53235	81959	0.650	154	0.648	0.002
90	06/12/2009	53700	83169	0.646	154	0.644	0.002
91	07/12/2009	53870	83169	0.648	154	0.646	0.002
92	08/12/2009	53583	83292	0.643	154	0.641	0.002
93	09/12/2009	53607	83221	0.644	154	0.642	0.002
94	10/12/2009	53567	83265	0.643	154	0.641	0.002
95	11/12/2009	53202	83294	0.639	154	0.637	0.002
96	12/12/2009	53465	82927	0.645	154	0.643	0.002
97	13/12/2009	52893	81923	0.646	154	0.644	0.002
98	14/12/2009	48943	73118	0.669	154	0.667	0.002
99	15/12/2009	50805	75349	0.674	154	0.672	0.002
100	16/12/2009	52074	78666	0.662	154	0.660	0.002
101	17/12/2009	53207	80731	0.659	154	0.657	0.002
102	18/12/2009	53105	80568	0.659	154	0.657	0.002
103	19/12/2009	53578	81354	0.659	154	0.657	0.002
104	20/12/2009	53312	81282	0.656	154	0.654	0.002
105	21/12/2009	53140	81567	0.651	154	0.650	0.002
106	22/12/2009	53136	81499	0.652	154	0.650	0.002
107	23/12/2009	53436	81511	0.656	154	0.654	0.002
108	24/12/2009	53546	81300	0.659	154	0.657	0.002
109	25/12/2009	54706	83278	0.657	154	0.655	0.002

The effects of the two developments on the performance were not identical, since the specific power forecasting is not the same for the two cases as shown in Tables 2 and 3. Table 4 shows the actual oxygen specific power and oxygen specific power forecasting as a result of the two developments.

Table 4. Real and forecasted oxygen specific power.

No.	Date	Real O <sub>2</sub> specific power (Kw/Nm <sup>3</sup> )	1 <sup>st</sup> Development	2 <sup>nd</sup> Development
			O <sub>2</sub> specific power forecasting in heaters power (Kw/Nm <sup>3</sup> )	O <sub>2</sub> specific power forecasting in pressure drop (Kw/Nm <sup>3</sup> )
1.	08/09/2009	2.357 (not used)	2.325	2.349
2.	09/09/2009	0.673	0.663	0.671
3.	10/09/2009	0.677	0.665	0.675
4.	11/09/2009	0.675	0.663	0.673
5.	12/09/2009	0.674	0.663	0.672
6.	13/09/2009	0.673	0.663	0.671
7.	14/09/2009	0.678	0.667	0.676
8.	15/09/2009	0.683	0.672	0.681
9.	16/09/2009	0.676	0.665	0.674
10.	17/09/2009	0.676	0.665	0.674
11.	18/09/2009	0.679	0.668	0.677
12.	19/09/2009	0.693	0.681	0.690
13.	20/09/2009	0.693	0.682	0.691
14.	21/09/2009	0.692	0.680	0.690
15.	22/09/2009	0.692	0.680	0.690
16.	23/09/2009	0.694	0.682	0.692
17.	24/09/2009	0.692	0.680	0.690
18.	25/09/2009	0.694	0.682	0.691
19.	26/09/2009	0.691	0.681	0.689
20.	27/09/2009	0.686	0.674	0.684
21.	28/09/2009	0.682	0.670	0.680
22.	29/09/2009	0.686	0.674	0.684
23.	30/09/2009	0.686	0.675	0.684
24.	01/10/2009	0.695	0.683	0.693
25.	02/10/2009	0.685	0.674	0.683
26.	03/10/2009	0.681	0.669	0.678
27.	04/10/2009	0.681	0.670	0.679
28.	05/10/2009	0.691	0.679	0.688
29.	06/10/2009	0.804 ( unit upset)	0.790	0.801
30.	07/10/2009	0.693	0.681	0.691
31.	08/10/2009	0.679	0.668	0.677
32.	09/10/2009	0.669	0.658	0.667
33.	10/10/2009	0.666	0.656	0.664
34.	11/10/2009	0.664	0.654	0.663
35.	12/10/2009	0.664	0.654	0.663
36.	13/10/2009	0.666	0.655	0.664
37.	14/10/2009	0.667	0.656	0.665
38.	15/10/2009	0.67	0.659	0.668
39.	16/10/2009	0.67	0.659	0.668
40.	17/10/2009	0.698	0.684	0.695
41.	18/10/2009	0.688	0.677	0.686
42.	19/10/2009	0.687	0.676	0.685
43.	20/10/2009	0.691	0.678	0.688
44.	21/10/2009	0.69	0.678	0.688
45.	22/10/2009	0.69	0.678	0.687
46.	23/10/2009	0.694	0.682	0.691
47.	24/10/2009	0.694	0.683	0.692
48.	25/10/2009	0.692	0.680	0.690
49.	26/10/2009	0.698	0.686	0.696
50.	27/10/2009	0.702 (Highest Value)	0.690	0.700
51.	28/10/2009	0.693	0.680	0.691
52.	29/10/2009	0.684	0.672	0.682
53.	30/10/2009	0.688	0.677	0.685
54.	31/10/2009	0.696	0.683	0.694
55.	01/11/2009	0.683	0.671	0.680
56.	02/11/2009	0.677	0.666	0.675

57.	03/11/2009	0.682	0.671	0.680
58.	04/11/2009	0.674	0.665	0.672
59.	05/11/2009	0.669	0.659	0.667
60.	06/11/2009	0.668	0.657	0.666
61.	07/11/2009	0.666	0.655	0.664
62.	08/11/2009	0.667	0.656	0.665
63.	09/11/2009	0.664	0.653	0.662
64.	10/11/2009	0.664	0.653	0.662
65.	11/11/2009	0.67	0.659	0.668
66.	12/11/2009	0.67	0.659	0.668
67.	13/11/2009	0.667	0.656	0.665
68.	14/11/2009	0.67	0.658	0.668
69.	15/11/2009	0.678	0.666	0.676
70.	16/11/2009	0.662	0.651	0.661
71.	17/11/2009	0.662	0.651	0.660
72.	18/11/2009	0.657	0.647	0.655
73.	19/11/2009	0.659	0.648	0.657
74.	20/11/2009	0.688	0.676	0.686
75.	21/11/2009	1.040 (unit upset)	0.278	0.282
76.	22/11/2009	3.820 (unit upset)	0.469	0.478
77.	23/11/2009	0.723 (unit upset)	0.712	0.721
78.	24/11/2009	0.676	0.664	0.674
79.	25/11/2009	0.672	0.660	0.670
80.	26/11/2009	0.672	0.661	0.670
81.	27/11/2009	0.658	0.649	0.656
82.	28/11/2009	0.663	0.652	0.661
83.	29/11/2009	0.658	0.648	0.656
84.	30/11/2009	0.654	0.645	0.653
85.	01/12/2009	0.655	0.644	0.653
86.	02/12/2009	0.652	0.642	0.650
87.	03/12/2009	0.653	0.643	0.651
88.	04/12/2009	0.655	0.644	0.653
89.	05/12/2009	0.65	0.640	0.648
90.	06/12/2009	0.646	0.636	0.644
91.	07/12/2009	0.648	0.637	0.646
92.	08/12/2009	0.643	0.635	0.641
93.	09/12/2009	0.644	0.634	0.642
94.	10/12/2009	0.643	0.633	0.641
95.	11/12/2009	0.639 (Lowest Value)	0.630	0.637
96.	12/12/2009	0.645	0.634	0.643
97.	13/12/2009	0.646	0.635	0.644
98.	14/12/2009	0.669	0.659	0.667
99.	15/12/2009	0.674	0.663	0.672
100.	16/12/2009	0.662	0.652	0.660
101.	17/12/2009	0.659	0.648	0.657
102.	18/12/2009	0.659	0.650	0.657
103.	19/12/2009	0.659	0.647	0.657
104.	20/12/2009	0.656	0.645	0.654
105.	21/12/2009	0.651	0.642	0.650
106.	22/12/2009	0.652	0.642	0.650
107.	23/12/2009	0.656	0.645	0.654
108.	24/12/2009	0.659	0.647	0.657
109.	25/12/2009	0.657	0.646	0.655
<b>Average</b>		0.672	0.662	0.671

The average of the actual oxygen specific power is 0.672 Kw/Nm<sup>3</sup>. The average for oxygen specific power of the first development is 0.662 Kw/Nm<sup>3</sup>, which is less than the actual oxygen specific power by 1.5%. The average of the second development is 0.671 Kw/Nm<sup>3</sup>, which is less than the actual oxygen specific power by 0.14%. Figure 7 shows the actual oxygen specific power and the oxygen specific power forecasting for the two cases.

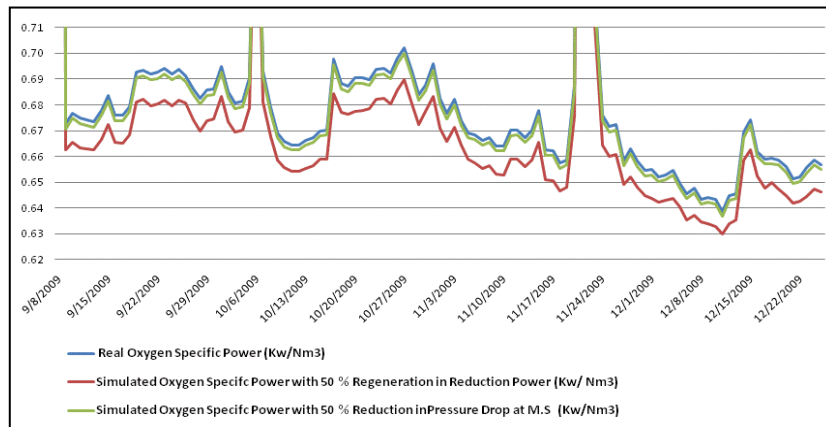

Fig. 7. Oxygen specific power comparison.

The results showed very minimal impact on the current oxygen specific power as a result of the modification for molecular sieve vessel layout, where two beds can be used in parallel. The results showed bigger impact on the current oxygen specific power of as a result of the adoption for a new molecular sieve, which means the investment on new MS is more profitable than the investment on modification of bed layout.

## 7. Conclusion

The technological forecasting for air separation unit purification system is suggested in this paper: new molecular sieve that will consume 50% less power, and new molecular sieve vessel configuration by redesigning the molecular sieve vessel layout.

The impact of these two forecasted methods on the unit used in this paper was evaluated. For the first method, the forecasted oxygen specific power resulted by this development showed drops in the actual oxygen specific power from  $0.672 \text{ Kw/Nm}^3$  to  $0.662 \text{ Kw/Nm}^3$ , which is equivalent to 1.5% reduction in total power consumption.

The second method was the redesign of molecular sieve vessel layout, where the pressure drop across the molecular sieve system can be reduced to 50%, the forecasted oxygen specific power resulted by this development showed a drop in the actual oxygen specific power from  $0.672 \text{ Kw/Nm}^3$  to  $0.671 \text{ Kw/Nm}^3$ , which is equivalent to 0.14%. These results encourage the investment on the new MS, which is more profitable than the choice of modification of the MS vessels layout.

## References

- [1] J. R. Meredith, S. J. Mantel, *Technological Forecasting*, John Wiley & Sons, Inc., 1995.
- [2] K. Narayanan, and S. Bhat, "Technology sourcing and its determinants: a study of basic chemical industry in India", *Technovation*, vol. 29, pp. 562-573, 2009.
- [3] R. Andrews, "Medtech executives can improve strategic planning with a structured method for exploring emerging technologies," *MX Magazine*, May 2006.
- [4] D. D. Wu, and D. L. Olson, "Introduction to special section on 'risk and technology'," *Technol. Forecast. Soc.*, vol. 77, pp. 837-839, 2010.
- [5] S. Mishra, S. G. Deshmukh, and P. Vrat, "Matching of technological forecasting technique to a technology," *Technol. Forecast. Soc.*, vol. 69, pp. 1-27, 2002.
- [6] J. Armstrong, "Combining forecasts: The end of the beginning or the beginning of the end?" *Int. J. Forecasting*, vol. 5, no. 4, pp. 585-588, 1989.
- [7] M. Y. Wang, and W. T. Lan, "Combined forecast process: Combining scenario analysis with the technological substitution model," *Technol. Forecast. Soc.*, vol. 74, pp. 357-378, 2007.

- [8] F. M. Tseng, A. C. Cheng, and Y. N. Peng, "Assessing Market penetration combining scenario analysis, Delphi, and the technological substitution model: the case of the OLED TV market," *Technol. Forecast. Soc.*, vol.76, pp. 897-909, 2009.
- [9] R. M. Thorogood, "Developments in air separation," *Gas Sep. Purif.*, vol. 5, pp. 83-94, 1991.
- [10] A. R. Smith, and J. Klosek, "A review of Air separation technologies and their integration with energy conversion processes," *Fuel Process. Technol.*, vol. 70, pp. 115-134, 2001.
- [11] W. F. Castle, "Air separation and liquefaction: recent developments and prospects for the beginning of the new millennium," *Int. J. Refrig.*, vol. 25, pp. 158-172, 2002.
- [12] D. R. Vinson, "Air separation control technology," *Comput. Chem. Eng.*, vol. 30, pp. 1436-1446, 2006.
- [13] T. Hidano, M. Nakamura, and M. Kawai, Patent No. US 2007/0209518 A1.US, 2007.
- [14] D. Shuguang, Patent No. EP 2002/1254695 A1.EU, 2002.
- [15] P. Seaton, Patent No. 2006/0230928 A1. USA, 2006.